

Woodpeckers[®]

CLAMP RACK-IT[™] SYSTEM

OWNER'S MANUAL

Woodpeckers Clamp Rack-It System is a fully adjustable, expandable space saving solution for storing all of your woodworking clamps. The incremental spacing and two tiered arms enable you to configure the system to fit your clamp storage needs, regardless of size, style, or number.

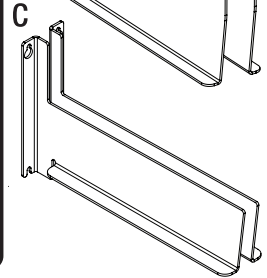
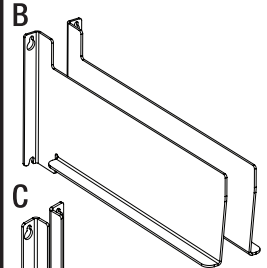
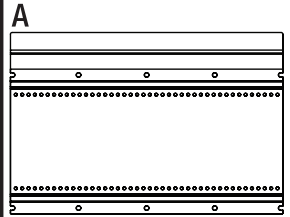

	CRIS-6A	CRIS-6B	CRIS-6C	CRIS-16	CRIS-24	CRIS-32
A. Backer Plate	1 (6")	1 (6")	1 (6")	1 (16")	1 (24")	1 (32")
B. Large Arm Set* Left & Right Side	1	2	X	3	3	3
C. Small Arm Set* Left & Right Side	1	X	2	2	2	2
1/4" x 1-3/4" Lag Bolts	2	2	2	4	4	6
1/4" Washers	2	2	2	4	4	6

* (4) 10-32 x 3/8 Thread-Forming Screws are included with each Arm Set

If you think you're missing anything, email us at mailroom@woodpeck.com.
You can also call us at 800-752-0725 from 9:00 a.m. to 5:00 p.m. EST Monday - Friday.

INSTALLING A SINGLE CLAMP RACK-IT SYSTEM BACKER PLATE

1. Find the location for the Clamp Rack-It Backer Plate on your wall. The Backer Plate must be located where the Lag Bolts will be securely fastened to a stud or wood wall.

WARNING! It is not recommended to install directly into drywall or lower strength wall types.

2. Drill pilot holes for top left and right Lag Bolts (center position for the 6" Backer Plate). **Ensure they are level.** Use the chart to the right to set the spacing.

FIGURE A.

FIGURE A

PILOT HOLE SPACING CHART	Lag Bolt Horizontal Spacing	Lag Bolt Vertical Spacing
6" Backer Plate	N/A	7-3/16"
16" Backer Plate	15-3/4"	7-3/16"
24" Backer Plate	23-3/4"	7-3/16"
32" Backer Plate	31-3/4"	7-3/16"

NOTE: If installing multiple Backer Plates, refer to page 3 "INSTALLING CLAMP RACK-IT SYSTEM MULTIPLE BACKER PLATES" instructions.

3. Install one of the Lag Bolt with Washer and thread in about half way into the pilot hole in the stud.

4. Align the top opening of the of the Backer Plate onto the installed Lag Bolt. FIGURE B / FIGURE B-1. Snug the Lag Bolt. FIGURE B-2.

5. While holding the Backer Plate in place, install the second Lag Bolt and Washer through the top opening of the Backer Plate into the second pilot hole. Snug the Lag Bolt.

6. Mark the locations for the two bottom Lag Bolts, pre-drill a pilot hole and install the 2 Lag Bolts with 2 Washers.

7. Tighten all of the Lag Bolts.

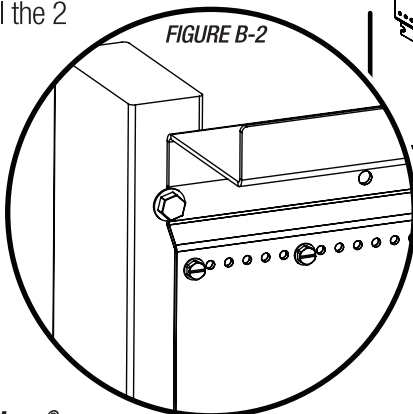
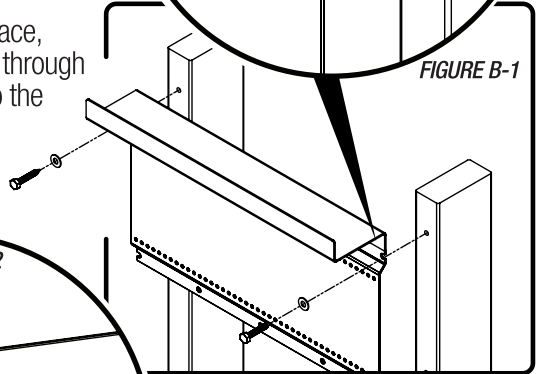
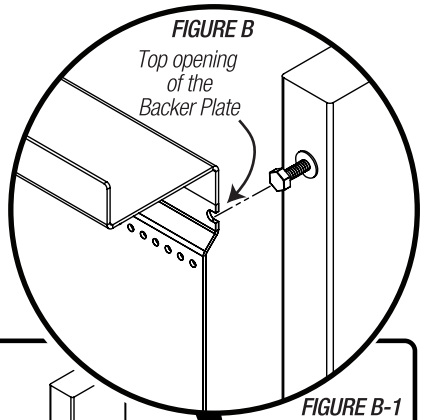

8. **32" NOTE:** For added support, the 32" Backer Plate, has additional mounting locations in the center of the Backer plate. Pre-drill pilot holes in the center locations and install the additional 2 Lag Bolts with 2 Washers.

INSTALLING CLAMP RACK-IT SYSTEM MULTIPLE BACKER PLATES

The Clamp Rack-It System Backer Plates are designed to work as stand alone or inline mounting. When mounting the Backer Plates inline, the spacing will be a bit different than stand alone. Determine the central hole location, then measure out from that hole. *FIGURE C*

FIGURE C

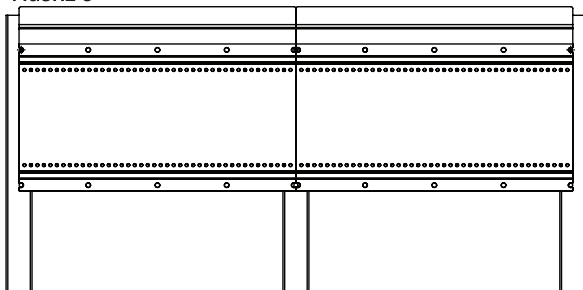

1. Find the location for the Clamp Rack-It Backer Plate on your wall. The Backer Plate must be located where the Lag Bolts will be securely fastened to a stud or wood wall.

WARNING! *It is not recommended to install directly into drywall or lower strength wall types.*

2. Drill pilot holes for top left and right Lag Bolts. **Ensure they are level.** Use the chart to the right to set the spacing for multiple Backer Plates. *FIGURE D.*

FIGURE D

MULTIPLE BACKER PLATE PILOT HOLE SPACING CHART	Lag Bolt Horizontal Spacing	Lag Bolt Vertical Spacing
16" Backer Plate	15-7/8"	7-3/16"
24" Backer Plate	23-7/8"	7-3/16"
32" Backer Plate	31-7/8"	7-3/16"

There are no provisions for installing multiple 6" Backer Plates in-line.

Follow Steps 3-8 on page 2 to continue installation.

INSTALLING THE ARMS OF THE CLAMP RACK-IT SYSTEM

Installation is the same for both the Large and Small Arm Sets. Measure the width of the bar on your clamp. This will determine the amount of space that is necessary between the left and right Arms to fit your clamps.

1. Identify the Left and the Right Arm of each Arm Set. The lip of the Arms should both face outward to form the rack. *FIGURE E*

2. With the location determined, install the Thread-Forming Screws for one Arm into the top and bottom positions of the Backer Plate. Leave at least an 1/8" gap between the plate and the screw head.

FIGURE E

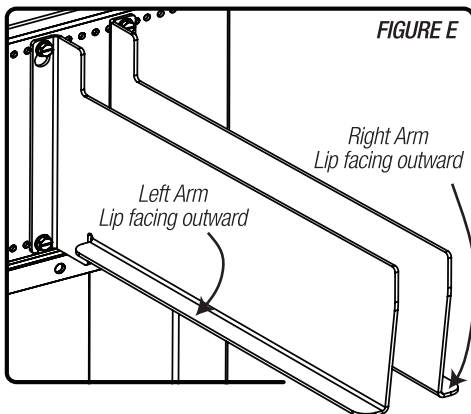

3. Slot the bottom opening of the left Arm around the lower Thread-Forming Screw, then slide the offset keyhole slot over the top Thread-Forming Screw. *FIGURE F*

4. Slide the left Arm down so the top of the keyhole slot is resting on the Thread-Forming Screw.

5. Tighten the two Thread-Forming Screws.

6. Leaving the width of your bar clamp in between the left and the right Arm, install the right Arm.

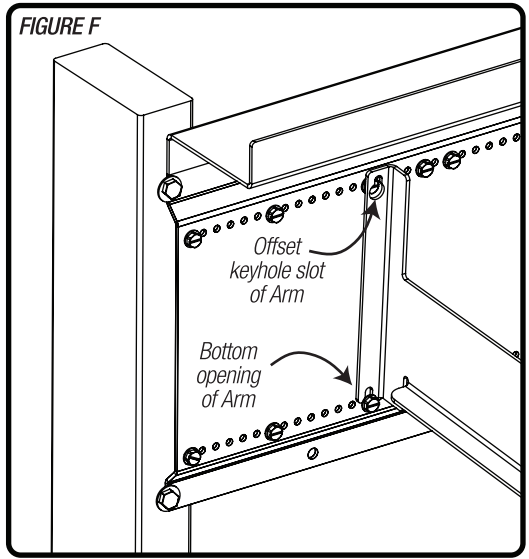

Woodpeckers®

PRECISION WOODWORKING TOOLS

Woodpeckers, LLC Strongsville, Ohio · woodpeck.com

© 2019 Woodpeckers, LLC

REV041719



WARNING! This product can expose you to chemicals, including chromium, which is known to the State of California to cause cancer and birth defects or other reproductive harm. For more information go to www.P65Warnings.ca.gov